



INSTALLATION AND OPERATING INSTRUCTIONS FOR AUTOMATIC INSTANTANEOUS TYPE WATER HEATERS FOR USE WITH NATURAL AND LIQUEFIED PETROLEUM GAS

MODEL 125B LP and 125B NG (Flow Modulated) Suitable for water (potable) heating and space heating

Intended for variable flow applications with steady cold water inlet temperatures. For preheated domestic hot water, install the 125 BS model. For recirculating applications, install the 125 BL model.



WARNING

If the information in this manual is not followed exactly, a fire or explosion may result causing property damage, personal injury or death.

FOR YOUR SAFETY

Do not store or use gasoline or other flammable, combustible or corrosive vapors and liquids in the vicinity of this or any other appliance.

WHAT TO DO IF YOU SMELL GAS

- Do not try to light any appliance.
- Do not touch any electrical switch; do not use any phone in your building.
- Immediately call your gas supplier from a neighbor's phone. Follow the gas supplier's instructions.
- If you cannot reach your gas supplier, call the fire department.
- Installation and service must be performed by a qualified installer, service agency or the gas supplier.

TABLE OF CONTENTS

Specifications	Page 2
Rules for safe operation	Page 4
Locating the Heater	Page 5
Combustion Air Requirements	Page 5
Mounting the Heater	Page 6
Venting the Heater	Page 6
Gas Connections	Page 7
Water Connections	Page 8
Safety before lighting the pilot	Page 8
Lighting instructions	Page 9
Setting water temperature	Page 9
Maintenance & Service	Page 9
Trouble Shooting	Page 10
Diagram of AquaStar	Page 13
Components and Parts List	Page 14

WARNING: Improper installation, adjustment, alteration, service or maintenance can cause injury or property damage. Refer to this manual. For assistance or additional information consult a qualified installer, service agency or the gas supplier. Upon completion of the installation, these instructions should be handed to the user of the appliance for future reference.

FEATURING: Automatic Variable Power Modulating Gas Valve

This well engineered, gas water heater has all the features a water heater should have:

It operates on the principle of heating water instantaneously "on demand". When a hot water faucet is opened, cold water flows through the coils of the heat exchanger in the Aquastar. This same flow opens the gas valve, and the burners are ignited by the pilot flame. The heat exchanger coils absorb the heat generated by the burners and transfer heat to the water. When the hot water faucet is shut off, the gas valve automatically closes and the burners turn off. Your hot water faucet is an ignition key to turn on the water heater, giving you control over your hot water energy use. Each time you turn off your hot water faucet, you also shut off the water heater.

FEATURES

- High Quality Materials for Long Working Life.
- Copper heating coils for endless supply of hot water.
- Burner output proportional to hot water flow demand for maximum energy efficiency.
- Safety thermocouple at pilot burner.
- Automatic overheating protection shut-off sensor.
- Stainless steel burners with stabilized blue flame.
- Built-in corrosion resistant draft inducer.
- Compact space saver: mounts on a wall with two hooks.
- Easily removable one-piece cover.
- Easy one person installation.
- Adjustable water flow restrictor to ensure that water flow demand will not exceed the heating capacity of the heater.
- Easy pilot flame lighting with push button piezo ignition.

AquaStar 125B LP and 125B NG Specifications

- Gas Input max.: 117,000 Btu/hr
min.: 28,000 Btu/hr
- Water Connection 1/2" Thread fitting
- H x W x D 29 3/4" x 18 1/4" x 8 3/4"
- Vent 5"
- Gas Connection 1/2" NPT thread
- Min. Water Pressure 18 Psi at 4 GPM
- Max. Water Pressure 150 Psi
- Shipping Weight 42 LB
- Net Weight 39 LB
- 1.8 GPM at 90° rise
- 3.7 GPM at 45° rise
- Min. Water Flow 1/2 gal/min
- LP GAS Supply Pressure inlet. min. 11" W.C.
max. 14" W.C.*
- LP GAS Manifold pressure 9.0" W.C.**
- Natural Gas Pressure inlet min.: 7" W.C.
max.: 14" W.C.*
- Natural Gas Manifold Pressure 4.2 W.C.**
- * Inlet gas pressure must not exceed this value
- ** For purposes of input adjustment

UNPACKING THE AQUASTAR HEATER

This heater is packed securely. The box includes two water connection fittings, a gas pressure regulator, an incandescent particle tray, two hooks for hanging the heater, this manual, a personal letter, a warranty statement and a warranty registration card. Do not lose this manual, as there is a charge for replacement. Please complete and return the enclosed warranty registration card.

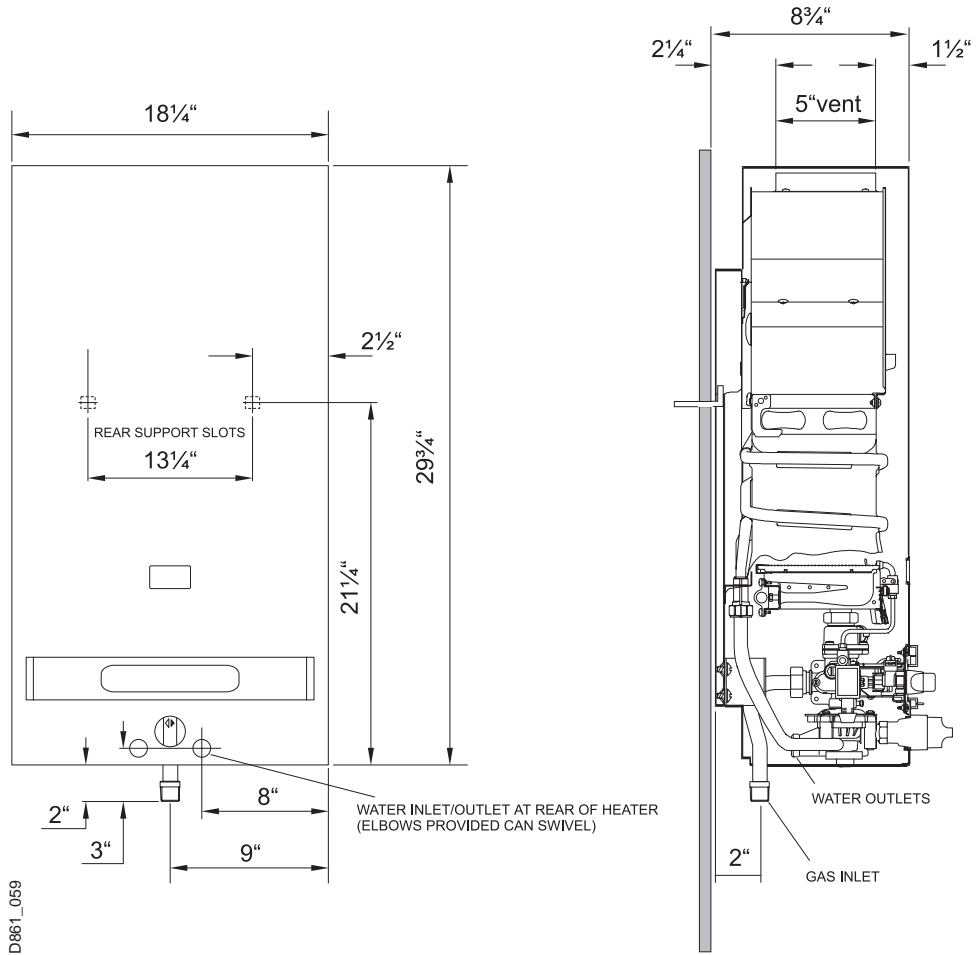

FRONT VIEW

SIDE VIEW

MINIMUM INSTALLATION CLEARANCES FROM COMBUSTIBLE AND NON COMBUSTIBLE MATERIALS FOR ALCOVE INSTALLATIONS

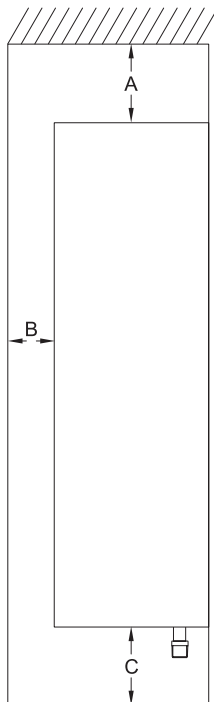

	MODEL 125B / 125B LOW PRESSURE / 125B SOLAR / 125X
TOP (A)	12"
FRONT (B)	OPEN
BACK	0"
SIDES	4"
FLOOR (C)	12"
FLUE DIAMETER	5"

AQUASTAR MODELS 125B / 125BL / 125BS / 125X

If you are using the AquaStar for combined space heating and potable water heating (see *schematic diagram below*), all piping and other components connected to the system must be suitable for potable water, (b) toxic chemicals such as those commonly used for boiler treatment to prevent corrosion and freezing must not be introduced into the system, and (c) if the space heating requires water temperatures higher than those required for domestic, potable water, a mixing valve or other similar device must be provided to reduce scald hazard potential, (d) maximum system water temperature must not exceed 140°F (60°C). **DO NOT CONVERT AN EXISTING, CLOSED HOT WATER HEATING SYSTEM TO A COMBINATION SPACE AND POTABLE WATER HEATING SYSTEM USING THE AQUASTAR OR ANY OTHER HEAT SOURCE.**

Open loop potable water and combination space heating system*

* To be used with a tank, check local codes. May not be permitted in some jurisdictions.

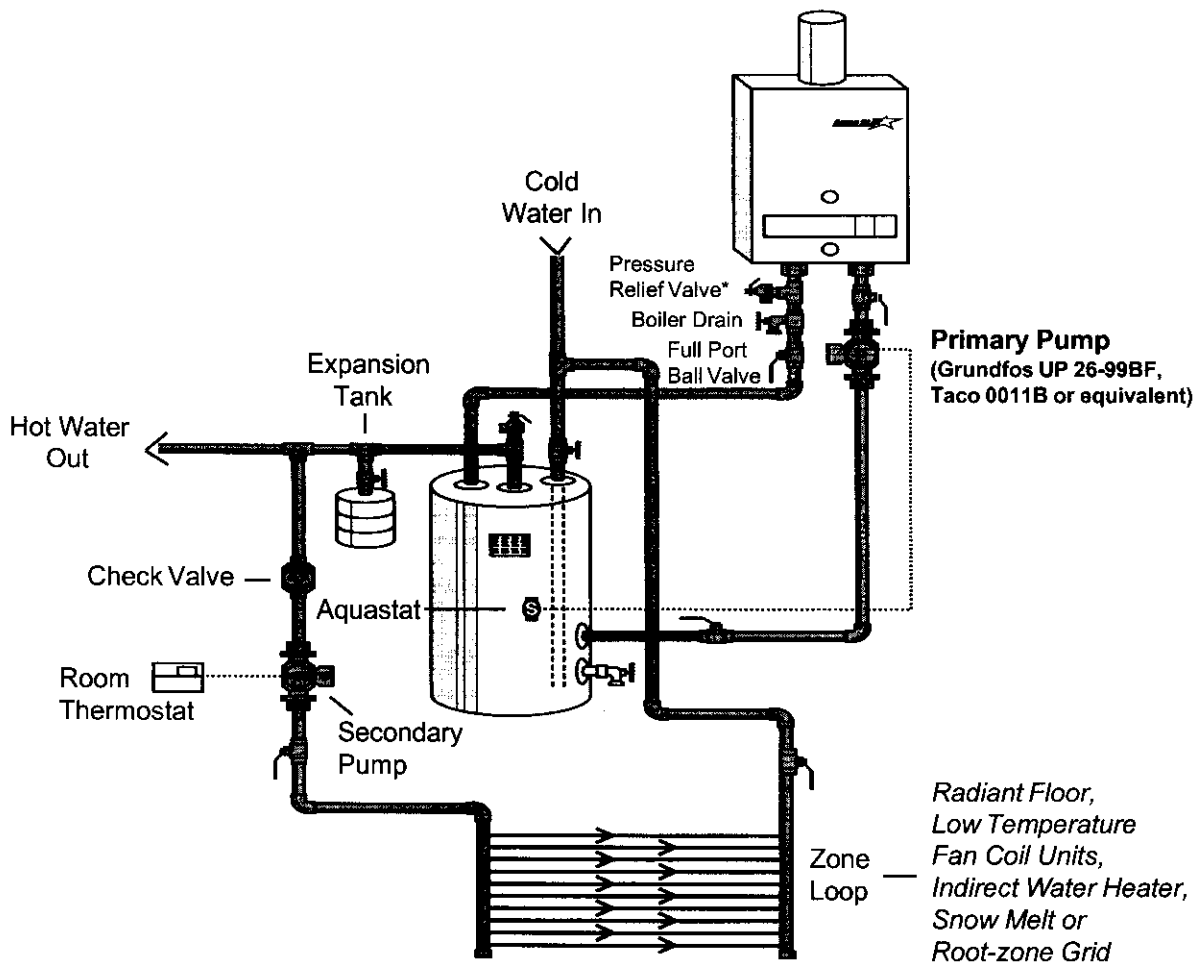

1. Maximum operating temperature of 125B: 140°F
2. Maximum heating capacity:

	40°F rise	20°F rise
AquaStar 125B -	80,000 BTU/hr	40,000 BTU/hr
3. System shown is electric storage tank with recirculating supply drawn from the tapping for the lower heating element.
4. Schematic is for illustration and example only and must not be used for actual installation without appropriate engineering and technical advice from a professional properly licensed in the locality where the installation is made.

GENERAL RULES TO FOLLOW FOR SAFE OPERATION

1. You should follow these instructions when you install your heater. In the United States: The installation must conform with local codes or, in the absence of local codes, the National Fuel Gas Code ANSI Z223.1/NFPA 54. In Canada: The Installation should conform with CGA B149.(1,2) INSTALLATION CODES and /or local installation codes.

2. Carefully plan where you install the heater. Correct combustion air supply and flue pipe installation are very important. If not installed correctly, fatal accidents can be caused by lack of air, carbon monoxide poisoning or fire.

3. The place where you install the heater must have enough ventilation. The National Fire Codes do not allow water heater installation in bathrooms, bedrooms or any occupied rooms normally kept closed. See the section below on locating the heater.

4. You must vent your heater. See section on Vent Pipe Connections, Page 5.

5. The appliance must be disconnected from the gas supply piping system during any pressure testing at pressures in excess of 1/2 Psig (3.5 kPa).

The appliance must be isolated from the gas supply piping system by closing its individual manual shutoff valve during any pressure testing of the gas supply piping system at test pressures equal to or less than 1/2 Psig (3.5Kpa). The appliance and its gas connection must be leak tested before placing the appliance in operation.

6. Keep water heater area clear and free from combustibles and flammable liquids. Do not locate the heater over any material which might burn.

7. **Correct gas pressure** is critical for the optimum operation of this heater (see specifications on page 2). Gas piping must be sized to provide the required pressure at the maximum output of the heater, while all the other gas appliances are in operation. Check with your local gas supplier, and see the section on connecting the gas supply.

8. Should overheating occur or the gas supply fail to shut off, turn off the gas supply at the manual gas shut off valve on the gas line.

9. Do not use this appliance if any part has been underwater. Immediately call a qualified service technician to inspect the appliance and to replace any part of the control system and any gas control which has been underwater.

PROPER LOCATION FOR INSTALLING YOUR HEATER

Carefully select the location of your new heater. For your safety and for proper heater operation, you must provide an abundant supply of combustion air and a proper venting installation.

The heater may still operate even when improperly vented. It will, however, be less efficient and could eventually damage the heater. It could even result in human sickness or death due to oxygen deprivation and carbon monoxide poisoning. Follow the guidelines below:

1. Place your heater as close to a vent or chimney as possible.

2. National building codes require that you do not install this appliance in bathrooms, bedrooms, unvented closet or any occupied rooms normally kept closed.

3. Simultaneous operation of other appliances such as exhaust fans, ventilation systems clothes dryers, fireplaces or wood stoves could create a vacuum effect in your home which could cause dangerous combustion by-products to spill back into your home rather than venting to the outside through the flue. Confirm that your Aquastar is venting properly when all these other appliances are running. See section on venting.

Do not obstruct the flow of combustion and ventilation air to the appliance. If installed near a clothes dryer it is very important that the dryer be properly vented. Failure to properly vent a dryer could result in a gradual accumulation of lint on the water heater fin coils and burners, leading to a dangerous condition of venting blockage and poor unsafe combustion.

4. Your hot water lines should be kept short to save energy. It is always best to have hot water lines insulated. Having a floor drain or sink nearby is handy in case you need to drain water from your heater.

WARNING: The water in this water heater is cold and always remains cold except for the times that hot water is being used **DO NOT INSTALL IN AN AREA WHERE IT COULD FREEZE.**

This heater is neither designed for nor approved for outside installation.

WARNING: Flammable materials, gasoline, pressurized containers, or any other items or articles that are potentially fire hazards must NOT be placed on or adjacent to the heater. The appliance area must be kept free of all combustible materials, gasoline and other flammable vapors and liquids.

COMBUSTION AIR REQUIREMENTS

Observe the following instructions concerning combustion air.

Appliances located in unconfined spaces:

- a) An unconfined space is one whose volume is greater than 50 cubic feet per 1000 Btu per hour of the combined rating of all appliances installed in the space. That would be 5850 cubic feet for the AquaStar 125B alone.
- b) In unconfined spaces in buildings of conventional frame, masonry, or metal construction, infiltration is normally adequate to provide air for combustion, ventilation, and dilution of flue gasses.

Appliances located in confined spaces:) The confined space must be provided with two permanent openings, one commencing within 12 inches of the top and one commencing within 12 inches of the bottom of the enclosure. Each opening must have a minimum free area of one square inch per:

- 1000 Btu/hr if all air is taken from inside the building.
- 2000 Btu/hr if all air is taken from the outside by horizontal ducts.
- 4000 Btu/hr if all air is taken from the outside by direct openings or vertical ducts.

Louvers, grills and screens have a blocking effect. If the effective free area is not known, increase the sizes of your openings by 75% if your louvers are wood and by 30% if your louvers are metal. Refer to the National Fuel Gas Code for complete information. In buildings of tight construction all air should be taken from outside.

CLEARANCES

The Aquastar 125 B is design certified for installation on a combustible wall and for installation in an alcove with the minimum clearances to combustible and non-combustible construction listed below

- A. Top 12 inches (305 mm)
- B. Front Open
- C. Back 0 inches
- D. Sides 4 inch (102mm)
- E. Bottom 12 inches (306 mm)

Clearance from vent is dependent upon the clearance rating of the venting material used. For example: type B-1 vent is approved for 1 inch clearance, B-2 vent for 2 inch, etc.

Note: Minimum clearance to combustible materials should not be less than 6" for single wall flue pipe. Note that this clearance can be reduced if combustible material are protected as per table VI of the National fuel Gas Code or if Type B gas vent is used.

MOUNTING INSTALLATION

The Aquastar 125 B is design certified for mounting on a wall.

Do not install this appliance on a carpeted wall or over floor covering which is combustible, such as carpet. The heater must be mounted on a wall using appropriate anchoring materials. If wall is a stud wall sheathed with plasterboard, **it is recommended that support board(s), either 1x4's or 1/2" (minimum) plywood first be attached across a pair of studs and then the heater should be attached to the support boards. See Fig 1.** Expansion and contraction of piping due to changing water temperature in the pipes imparts movement to the heater which, if mounted directly to a brittle, friable board, such as plasterboard, can cause failure of mounting.

Before installing the unit, be certain you have the correct heater for your type of Gas – Propane or Natural Gas. Identification labels are found on the shipping box, and on the rating plate which is located on the right side panel of the cover. Also, each burner orifice is stamped with a number (79 for LPG and 120 for Natural Gas).

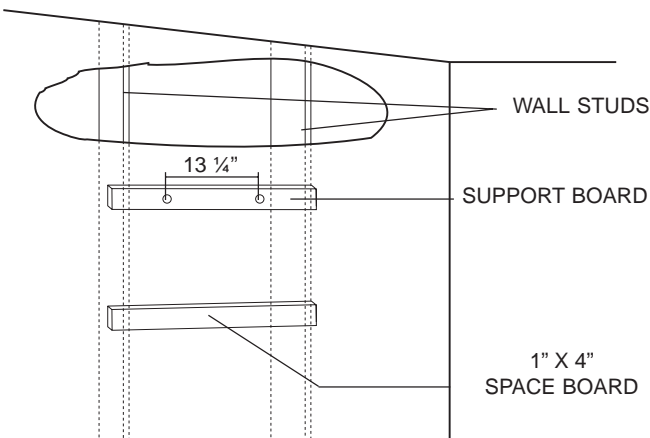

Fig. 1 - Mounting the Heater

The incandescent particle tray (shipped loose in the carton with the water heater) must be attached at the bottom of the water heater front cover at the time of installation. Use the screws provided. See figure 2

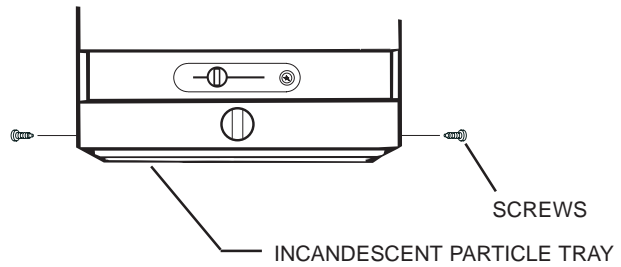

Fig. 2 - Incandescent Particle Tray Illustration

VENTING

Vent pipe connection. WARNING: Do not reduce the vent pipe size.

This appliance must be vented to the outside following all local ordinances and specifications for installing a gas appliance vent or chimney. The venting system must be designed and constructed so as to develop a positive flow adequate to remove flue gasses to the outdoors. **Minimum vent size must be 5". Minimum height must be 6 feet, provided there are no elbows. Termination of vent must be 2 feet above any obstruction within a 10 foot radius. Consult your gas utility or National Fuel Gas Code if vent will have elbows or share venting with another appliance. The vent connector should have as much vertical rise as possible (minimum 12") before any horizontal run.** The appliance must be located as close as practicable to a chimney or vent. The vent pipe sections must be secured to each other with sheet metal screws. Keep in mind the minimum clearance from the top of your heater. Remember also that single wall vent pipe connectors require a 6 inch clearance from combustibles. National Fuel Gas Code specifies double wall — Type "B" — vent pipe be used in cold climates and for gas vents running through attics. We consider double wall vent pipe preferable in all circumstances. Any vent section greater than 45 degrees from vertical is considered horizontal. Horizontal sections of vent connectors must slope upwards at least 1/4 inch for every foot of its horizontal length. Keep the horizontal section short and avoid too many elbows.

WARNING

Note: The burners of an instantaneous "on demand" water heater such as the AquaStar are only on at the time that hot water is actually being used, the venting stack is therefore cold except for the short durations when hot water is being used, it is therefore very important that the venting and air supply be adequate to provide a good positive draft as soon as the burners turn on. See venting guide on back page.

The AquaStar 125B instantaneous water heaters have built-in draft diverters and are designed for indoor installation only. The draft diverter outlet must be connected to a clear, unobstructed vent of the same size, or larger.

In Canada, CAN/CGA-B149 Installation Code for detailed requirements

In U.S.A., ANSI Z223.1 - NFPA 54, national Fuel Gas Code for detailed requirements.

The flue connection for the AquaStar 125B is 5 inches. However, in Canada, for installations at high altitude (2000-4500 feet above sea level) a six inch flue is required. A 5" by 6" flue adaptor must be affixed to the flue collar of the AquaStar with at least two screws. See figure 3

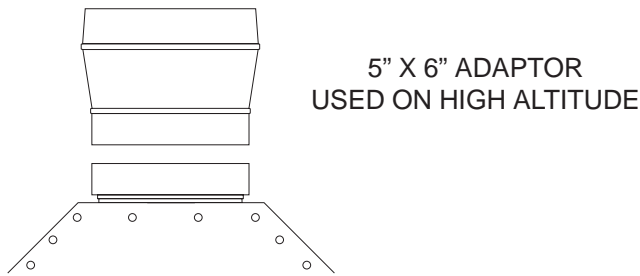

Fig. 3 - Flue Adaptor for High Altitude Installations

WARNING: Failure TO INCREASE THE VENT SIZE TO SIX INCHES AND/or assure that the manifold pressure is set to proper value listed for applications at high altitudes will cause unsafe venting, asphyxiation, and will void IAS Certification.

GAS CONNECTIONS and Gas Regulator

Before connecting the gas supply, check the rating plate on the right side of the front cover to be sure that the heater is rated for the same gas to which it will be connected.

In the United States: The installation must conform with local codes or, in the absence of local codes, the National Fuel Gas Code ANSI Z223.1/NFPA 54.

In Canada: The Installation should conform with CGA B149 INSTALLATION CODES and /or local installation codes.

NOTE: The Aquastar 125 B is supplied with a gas pressure regulator that must be installed on the heater before attaching the gas supply line. See figure 4. Failure to install the gas regulator as shown in figure 4 will be a violation of IAS certification of the unit. The regulator supplied with the heater is preset for the gas shown on the rating plate to the correct pressure. It is an appliance level regulator designed for (low inlet) pressure (less than 1/2 Psig or 15" W.C.) DO NOT connect to an unregulated or high pressure propane line or to a high pressure commercial natural gas line.

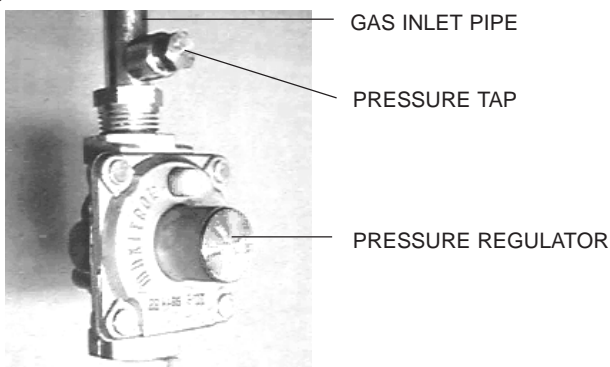

Fig. 4 - Installation of Gas Pressure Regulator

The pressure regulator provided with the heater is adjusted to deliver the proper gas pressure (as indicated on the rating plate and in the manual for altitude up to 2000 feet

(660 meters) above sea level. On appliances being installed above 2000 ft (660 meters) elevation, the inlet gas pressure should be set at installation to the value shown below.

NOTE: The gas pressures specified below refer to pressures taken at the test pressure nipple on the gas inlet pipe just above the regulator (See Fig 4). These readings should be taken while the heater is operating at full input — i.e. maximum water flow with the temperature dial selector turned all the way clockwise.

MAXIMUM INLET GAS FLOW PRESSURE SETTING

Altitude	Natural Gas inches W.C:	Liquid Propane inches W.C:
0' - 2.000 ft	5.7"	10.5"
2.000 ft - 4.500 ft	4.6"	8.4"

Above 4.500 ft consult your local gas supplier.

GAS LINE SIZE

It is strongly recommended that the natural gas pipe line be 3/4" for the entire distance. If the maximum length is above 40 feet, use 1" line. Flexible tubing is NOT recommended, but if it is to be used, oversize it. With LP gas installation, the recommended sizes are 5/8" up to a maximum of 20 feet distance, 3/4" up to 50 ft distance and 7/8" up to 100 feet.

National Fuel Gas Code requires that a sediment trap (drip leg) be installed on gas appliances not so equipped. The drip leg must be accessible and not subject to freezing conditions. Install in accordance with the recommendations of the serving gas supplier.

WARNING: The heater must be disconnected from the gas supply piping system during any pressure testing of that system at test pressures in excess of 0.5 psig.

The water heater must be isolated from the gas supply piping system by closing the manual shutoff valve during any pressure testing of the gas supply piping system at test pressures equal to or less than 0.5 psig.

The water heater, including the pressure regulator provided with it, must not be operated at gas supply pressures in excess of 0.5 psig. If overpressure has occurred, such as through improper testing of the gas lines or emergency malfunction of the supply system, the gas valve and regulator must be checked for safe operation. Make sure that the regulator vent is protected against blockage. Vent blockage could occur during ice storms.

When your connections are made, check for gas leaks at all joints (not just the ones you made). Apply some soapy water to all gas fittings and gas valve. **Soap bubbles are a sign of a leak.**

NOTE: Do not apply soap solution to pilot filter screen or pilot orifice area. If you have a leak, shut off the gas. After verifying that required gaskets are in place, tighten appropriate fittings to stop leak. Turn the gas on and check again with a soapy solution. **Never test for gas leaks using a match or flame.**

WATER CONNECTIONS

Although water piping throughout your structure may be other than copper, we recommend that copper piping be used for at least three feet before and after the heater (follow local codes if more stringent). Keep water inlet pipe to no less than 1/2 inch diameter to allow the full flow capacity. Remember that water pressure must be sufficient to activate the heater when drawing hot water from the top floor. If the hot and cold connections to the heater are reversed, the heater will not function. The AquaStar 125B is provided with two elbow type connectors that must be connected to the inlet and outlet fittings of the water valve as shown in Fig 5. These fittings seal to the water valve by means of a union connection with a washer type gasket at the joint. No pipe dope or thread tape is to be used at these joints. Be certain there are no loose particles or dirt in the piping. Blow out or flush the lines before connecting to the AquaStar. A ball valve should be installed on the cold water feed line to facilitate servicing the heater. For installation on a private well system, be sure that the **water pressure** is set between 30 and 50 psi.

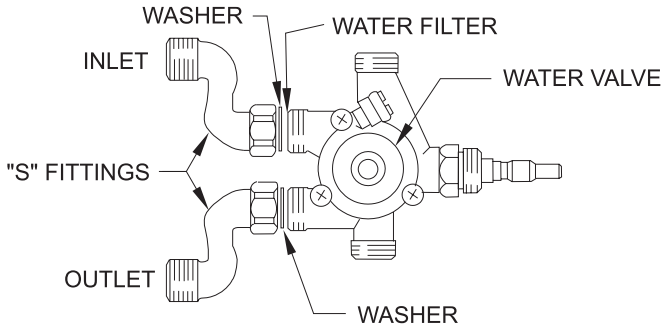

Fig. 5 - Water valve and Elbows water connectors, top view

Connecting the pressure relief valve (PRV)

A listed pressure relief valve supplied with the heater must be installed at the time of installation. No valve is to be placed between the PRV and the heater. No reducing coupling or other restriction may be installed in the discharge line. The discharge line must be installed such that it allows complete drainage of both the PRV and the line. The location of the PRV must be readily accessible for servicing or replacement, and be mounted as close to the water heater as possible. See Fig 6. To install the PRV, a suitable fitting connected to an extension on a "T" fitting can be sweated to the hot water line.

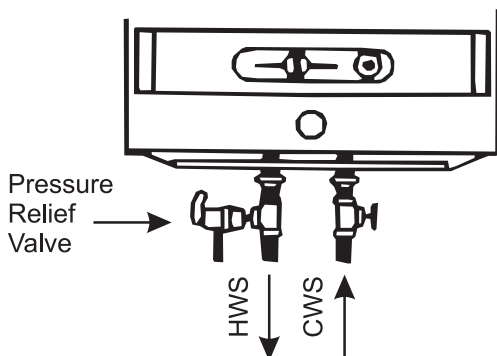

Fig. 6 - Pressure Relief Valve

OPERATING INSTRUCTIONS

Before proceeding with the operation of the heater make sure that the system is filled with water. Make sure the water heater drain plug is closed. See Figure 7 below.

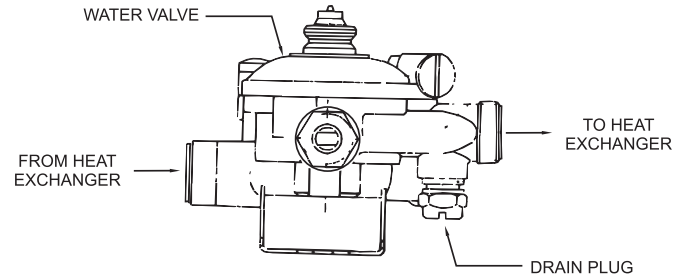

Fig. 7 - Water heater drain plug

Open the cold water inlet supply to the heater fully. Open a hot water faucet to permit the water to fill the heater and the piping and to eliminate the air trapped in the system. Close the hot water faucet after the water flows freely and all the air has escaped from the system. The water heater is now ready to work

FOR YOUR SAFETY READ BEFORE LIGHTING THE PILOT

Warning: If you do not follow these instructions exactly, a fire or explosion may result causing property damage, personal injury or loss of life

A. This appliance has a piezo-igniter for lighting the pilot burner. When lighting the pilot, follow these instructions exactly.

B. BEFORE LIGHTING smell all around the appliance area for gas. Be sure to smell next to the floor because some gas is heavier than air and will settle on the floor.

WHAT TO DO IF YOU SMELL GAS

- Do not try to light any appliance.
- Do not touch any electric switch; do not use any phone in your building
- Immediately call your gas supplier from a neighbor's phone. Follow the gas supplier's instructions.
- If you cannot reach your gas supplier, call the fire department.

C. Use only your hand to push in or turn the gas control buttons. Never use tools. If a button will not push in, check to make sure the buttons are being pushed in the proper sequence. Follow these instructions exactly. If control button(s) are jammed, close the gas supply and call a qualified service technician. Attempted forceful repair may result in a fire or explosion.

D. Do not use this appliance if any part has been under water. Immediately call a qualified service technician to inspect the appliance and to replace any part of the control system and any gas control which has been under water.

LIGHTING INSTRUCTIONS

1. STOP! Read the safety information above on this plate.
2. The Gas valve must be turned off by sliding the gas valve button to the far left under the OFF (●) mark.
3. Wait five (5) minutes to clear out any gas. If you smell gas, STOP! Follow "B" in the safety information above on this plate. If you don't smell gas, go to next step.
4. The pilot burner is located behind the peephole in the front center of the jacket directly below this instruction plate.
5. Slide the gas valve button to the right, under the pilot mark (⚡).
6. Fully depress gas valve button and light pilot by pushing "PILOT IGNITER" button (⚡). This step may have to be repeated.
7. Observe the pilot flame through the peephole. The gas valve button should be held down at least 10 seconds with pilot burning. When the gas valve button is released, the pilot should continue to burn.

- If the gas valve button does not pop up when released, stop and immediately call your service technician or gas supplier.
- If pilot does not stay lit, repeat steps 1 through 7.
- If pilot will not stay lit after several tries, slide the gas valve button to the left, under the OFF (●) mark and call service technician or gas supplier.

8. Slide the gas valve button to the right, under the ON mark (●●●). The heater will now fire when water is drawn at a rate greater than the threshold flow rate.

NOTE: If main burner should fail to ignite, make sure pilot is burning. If not, repeat lighting steps 1 through 7.

TO TURN OFF GAS TO APPLIANCE

Slide the gas valve button to the far left, under the off (●) mark and close the gas supply to the heater.

SETTING THE WATER TEMPERATURE

The AquaStar 125 B LP and 125 B NG water heaters have a gas control that modulates burner input in response to flow. Its purpose is to ensure that the hot water temperature will remain steady, although the water flow demand might vary (down to 1/2 gal/minute). To adjust the temperature on your AquaStar, turn on a hot water faucet to its maximum flow. At the water heater, turn the large knob located beneath the main gas controls on the front of the heater all the way to the right (clockwise). See Fig 8. This will produce a temperature rise of approximately 90°F at flow rates between 0.5 and 2.0 gallons per minute. Given that average incoming water temperatures are 50°F, this heater will produce approximately 140°F water at these flow rates. Turning the dial all the way to the left (counterclockwise) will produce a temperature rise of approximately 45°F for flow rates between 1.1 and 3.7 gallons per minute. It is safest to select a comfortable temperature and not have to mix in cold water.

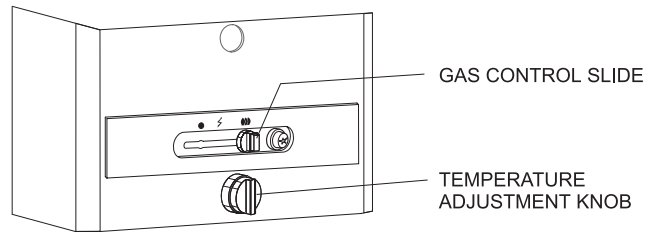

Fig. 8 - Water Flow Control Knob

What is the best temperature setting? Because AquaStar water heaters deliver endless hot water at the temperature you have selected, there is no need to produce very hot water and then mix in cold. It just does not make sense to overheat water and then mix in cold to cool it off. You cannot run out of hot water with an AquaStar, so set the dial for the temperature you prefer. Note: 105°F is the maximum recommended for a hot bath. The position you select on the temperature adjustment knob will depend on the temperature of the incoming water (50°F is average in the U.S.). In warm weather regions where the incoming cold water is generally warmer, or during the hot weather months in some other areas a midway setting on the temperature adjustment knob would produce a temperature rise of about 70°F, giving an output of approximately 120°F. At this setting, if it is still necessary, one could mix a small amount of cold water in a shower and have a comfortable shower at about 3 gallons/minute. During the colder months, or in cold climate areas, it might be necessary to set the control to the maximum position, all the way clockwise to the right.

If you supply the AquaStar 125B, with preheated water (i.e.) in a solar installation the unit could overheat. It will then shut off on safety when the outlet temperature reaches 194°F. For this type of application, purchase a solar model 125 B LPS or 125 B NGS.

MAINTENANCE AND SERVICE

Approximately once a year, the AquaStar should be checked, cleaned and serviced as necessary. To remove the front cover, first remove the incandescent particle tray, then pull off the temperature adjustment knob and unscrew and remove the plastic collar. Unscrew the central screw located at the bottom of the front cover. Pull main cover out toward you and lift up and out. THE FOLLOWING OPERATIONS SHOULD BE PERFORMED BY A QUALIFIED SERVICE PERSON:

Vent System: Should be checked annually. Clean and repair as needed.

Water Valve (Part # 8707002499): The water valve on this heater should be serviced periodically. The frequency will depend on the mineral content of the water and conditions of use or whenever signs of corrosion appear at the gas and water valve joint. Check that the water inlet filter (#28 on Figure 12, page 14) is clean.

Pilot Flame: The pilot flame should burn with a clean sharp blue flame and should resemble the diagram in Fig 9. If the flame is yellow, or if the pilot knob has to remain depressed for a long time in order to keep the pilot lit,

the pilot burner and or the pilot burner orifice may need to be cleaned, the orifice may need to be replaced, and or the air screen may need cleaning. The pilot flame should envelop approximately 10 mm (3/8") of the tip of the thermocouple. If it is too small, the pilot burner must be cleaned. To obtain a spark, the position of the Piezo igniter electrode should be approximately 3 mm (1/8") from the pilot burner tip.

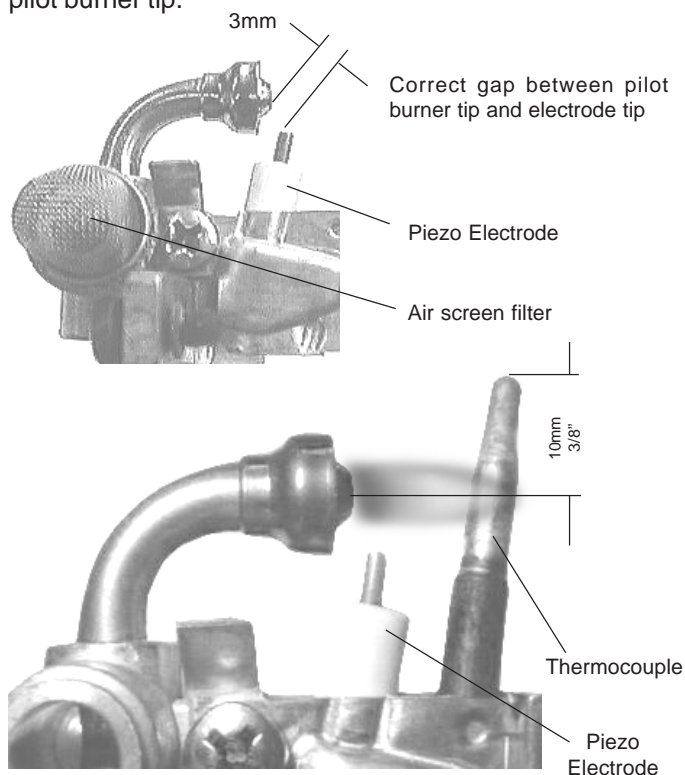

Fig. 9 - Characteristic Pilot Flame

To clean the pilot burner and/or the pilot orifice : Turn off the gas at the unit. Remove the cover of the heater. To do so, pull off the temperature adjustment knob and unscrew and remove the plastic collar and unscrew the central screw located at the bottom of the front cover. Pull main cover out toward you and lift up and out . Pull the air screen off, wash it and blow any lint off (See Fig 10). The pilot orifices should also be cleaned or replaced. **Do not enlarge the orifice.** Do not use any wire or sharp object to clean orifices. Natural gas orifices are large enough that you can usually clean them by blowing through them. LP orifices, on the other hand, are too small to clean and should be replaced. See #3 in Trouble Shooting Section. To access the pilot orifice, remove 2 screws holding pilot assembly in place. Then loosen compression fittings to expose pilot orifice.

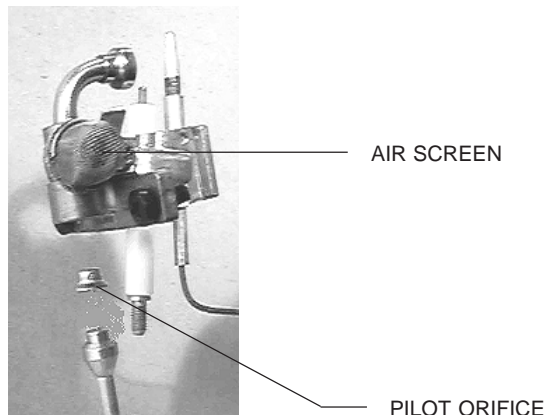

Fig. 10 - Pilot burner with air screen/ pilot orifice

Main Burner Flames: The main burner flames should be blue, with a more intense blue cone in the center core. Yellow flames could be a sign of wrong size gas orifices or dirty burners, or a blockage on the heat exchangers fins. If some burners have yellow flames while others have good flames, it is likely that dust, lint or spider webs have partially clogged the burner venturis. To clean the burners, contact a gas service person.

Mineral Scale Build-up: AquaStars, when operated at lower temperature settings, tend not to accumulate mineral buildup. If however, the heater is used at the higher temperature settings and the water has a high mineral content, periodic descaling may be necessary. The heating coils should be flushed with a descaling solution. Consult your dealer or Controlled Energy for instructions.

TROUBLE SHOOTING

Introduction

The AquaStar 125 burners are activated by a water flow valve. Numerous water related problems can cause this water valve to malfunction such as: Insufficient water flow volume to activate the burners at its minimum flow requirement; Dirt in the water flow valve causing it to malfunction; Sediment build-up in faucet aerators, or shower heads; Uneven pressures between cold and hot. (with single lever faucets) Plumbing cross overs. These water flow related problems can cause the heater to deliver less than its full output, or to fail to ignite or to shut down completely.

Problems are stated in upper case, bold face. Most common causes for the problems follow in order of likelihood. The suggested solutions require that the cover be taken off. To do this, remove incandescent particle tray, pull off the temperature adjustment knob and unscrew and remove the plastic collar and unscrew the central screw located at the bottom of the front cover. Pull main cover out toward you and lift up and out.

PILOT LIGHT WILL NOT LIGHT

1. No gas to the AquaStar

- A. Gas cock on gas line may not be open.
- B. Gas valve button has not been moved to "PILOT" position (⚡). Slide button to right to PILOT.
- C. Gas regulator may be shut or damaged.

2. In-line AquaStar gas regulator jammed (usually on LP gas)

Replace or unjam the regulator. **Note:** The regulator furnished with the heater is designed for low gas pressure. Excessive pressure will lock it up (propane only). Jamming usually happens if the gas pressure between the gas tank (propane) and the water heater's gas regulator has not been reduced. See page 2 for recommended correct gas pressure. To unjam a regulator, consult your gas supplier.

3. Pilot orifice clogged and/or air screen dirty, or pilot gas filter is dirty.

Clogging of the pilot burner can be caused by dust and any suspended matter contained in the ambient air.

Although the filters can lengthen the cleaning intervals, they can never completely prevent such clogging. In consequence the gas jet issuing from the pilot orifice is reduced and or the air mixture is reduced. The pilot flame is weak and thus can no longer heat the thermocouple sufficiently. For cleaning purposes, the air filter screen is pulled off, washed and blown out. The pilot orifice has likewise to be cleaned or exchanged. Consult Controlled Energy or a gas service person.

4. Air in the Gas Line

Note: Normally this is a problem only at the time of initial installation, after the pipes have been worked on, or after a propane tank has been allowed to empty, or after the heater has been shut down for a long time.

Bleed all the air trapped in the gas line. Because of the very small pilot orifice (especially on LP gas models), bleeding out all the air could take several minutes. Slide the gas valve button to pilot position (↖) and depress this button until all the air has escaped, and the gas has arrived. During this process, press repeatedly on the piezo ignition button until the pilot flame has ignited.

PILOT LIGHTS BUT FLAME GOES OUT WHEN BUTTON IS RELEASED

1. Pilot push button was not pushed in far enough or was not held in long enough

Once pilot flame has been lighted. Hold button pushed in for at least 15 seconds to give time for the pilot flame to properly heat the tip of the thermocouple.

2. Pilot flame improperly aimed or is too weak so it is not properly heating the tip of the thermocouple.

The Pilot flame should be a sharp blue flame and aimed at the tip of the thermocouple so that it envelops 10 mm (3/8 ") of the thermocouple tip. Pilot flame has to be properly aimed at the thermocouple. See Fig 9.

3. Poor thermocouple connection at the electromagnet

Note: Electromagnet is part #8707201012 located on the right side of the gas valve behind the piezo push-button assembly. Check the tightness of the thermocouple connection nut at the electromagnet: The Electro-magnet connection is a large aluminum 17mm hex head nut. The thermocouple end is a 5 mm brass nut which screws into the 17 mm nut. Tighten the thermocouple nut snugly but not too tight.

4. Poor circuit connections at the ECO. (Energy Cut-Off overheat protection)

Oxidation or looseness of the ECO terminal connections can result in millivolt current loss through the thermocouple safety circuit. Clean terminals with very fine sand paper or an eraser and reconnect ECO leads.

5. Faulty ECO (part #8707206040)

If cleaning the terminals attached to the ECO did not fix the problem, connect a jumper wire between the two wires and try to relight the pilot. If the pilot flame now remains on, replace the ECO. If the flame still goes out when the button is released, the ECO is not defective. Go to next step.

6. Faulty thermocouple (part #8747202083) or electromagnet) Unless these 2 parts are at least 8 to 10 years old, it is very unlikely that they are faulty. Before testing, reconfirm that #2 is absolutely correct, and that all connections are clean and tight.

To test the thermocouple, disconnect the thermocouple lead to the ECO. Insert a multi-meter probe on the thermocouple ECO connection and attach the other meter lead on the spade connector of the ECO. Light the pilot flame, and take a reading on the meter. If it reads less than 24mV, replace the thermocouple. If the reading is 24mV or over the thermocouple is good. To test the electromagnet, take another reading across the ECO spade while the pilot flame is on. The reading should drop to about 15 mV. If it does not and remains unchanged, replace the electromagnet.

BURNERS DO NOT IGNITE WHEN HOT WATER IS TURNED ON

1. Pilot is not on.

Light the pilot. See lighting instructions.

2. Gas valve button not positioned on Burner Position

Be sure pilot flame is on. Slide gas valve control to burner position (●●●).

3. Cold incoming water connection made to wrong side of heater

Make sure cold water inlet connection is on the right side of heater when you are facing heater.

4. Water flow rate at hot water tap is too low.

Note: When the flow control is turned all the way clockwise, the AquaStar models 125B require 1/2 gallon per minute flow to activate the burners. This is a flow which would fill a quart jar in 30 seconds. If the flow control knob is turned fully counterclockwise, a flow rate of 1.1 gpm is required to activate the burners.

5. Cold water inlet filter on heater is dirty.

Remove filter and clean. This screen filter is located at the inlet side of the brass water valve (fig. 12, #28). Check and clean faucet aerators too.

6. Crossover in household plumbing

The AquaStar burner activates when there is sufficient water pressure drop in the AquaStar water valve assembly — i.e. when a hot water faucet is opened. If there is a crossover in the plumbing, the necessary pressure drop in the AquaStar will be insufficient, or totally eliminated. A plumbing crossover can be caused by a bad washer at a single lever faucet or incorrect plumbing or a mixing valve in the line, etc. which permits hot and cold water to mix in the plumbing. The crossover will create a back pressure in the system preventing the pressure drop in the Aquastar — i.e. cold water is entering the water heater from both sides and the burners will not come on. To confirm there is no crossover in the plumbing, shut off the cold water supply to the AquaStar. Open your hot water taps. There should not be any water flowing. If there is water flowing, there is a crossover in the plumbing. This is a plumbing problem, not an Aquastar problem. Please contact your plumber.

7. Water valve parts may be dirty or components damaged.

Water valve and component parts must be totally free of dirt. First check that the venturi is free of dirt particles. In hard water areas, mineral deposits can eventually (3 to 5 years in hard water areas) corrode the water valve parts to a point where they will need replacing. *Any sign of moisture or corrosion at the joint of the water valve and the gas valve is a sign that the water valve assembly components need to be replaced immediately.* **Note:** Water valve for model 125B is part# 8707002499 for both LP and NG models. (Contact service person to clean water valve or replace if corrosion is present).

PILOT LIGHT GOES OUT DURING OR IMMEDIATELY AFTER HOT WATER HAS BEEN USED

1. Gas pressure too low

Very low gas pressure may be caused by low delivered gas pressure, a jammed gas regulator or undersized gas lines. If the gas lines are undersized, there may still be the specified static gas line pressure. However when the water valve opens, and gas enters the burners, the pressure could drop sharply, causing the pilot flame to go out. Have a gas technician confirm the gas pressure both static and at maximum Btu output. Specifications for your heater are on page 2.

2. Pilot may be dirty or weak

See Page 9 for instructions on pilot maintenance.

3. Burners are not shutting down immediately when hot water is turned off

Note: If burners don't shut down immediately when the hot water is turned off, the heater will overheat and the ECO will shut-off the gas. Rebuild the water valve assembly using the repair kit from CEC (part #8 703 406 178).

WATER IS TOO HOT

1. Temperature Selection too high

Turn the temperature adjustment knob counter-clockwise (to the left) to lower the maximum water temperature.

Note: This will increase the activation flow rate.

2. Inlet water temperature is too high (as with solar preheated water)

Note: Only the Model "S" AquaStar should be used if the inlet water is preheated.

3. Reduce inlet gas pressure

WATER IS NOT HOT ENOUGH

1. Temperature selection too low.

Change the setting. Turn the temperature adjustment knob clockwise (to the right).

Note: This will decrease the activation flow rate.

2. Water flow through the heater is higher than the capacity of the AquaStar to heat it

Reduce the flow demand at the faucet. See flow rates at specific temperature rises on page 2.

3. Btu input is too low due to insufficient gas pressure *It is extremely important for a tankless instantaneous water heater to have the right size gas line to obtain the correct gas pressure*

See specifications on page 2. Unlike storage tank water heaters, the burners of a tankless water heater must be very powerful to heat water instantaneously since they do this only at the time hot water is actually being used. It is therefore imperative that the gas pressure requirement be met exactly. Insufficient gas pressure will directly affect the water temperature at the time of usage. See page 2 for correct gas pressure settings and page 13 for locations where gas pressures are taken.

4. Btu input is too low due to insufficient gas supply

Make sure your main gas line is fully opened. If using LP gas, be sure that the size of the propane tank is adequate to supply the required gas pressure.

5. Cold water is mixing with the hot water between the AquaStar and the outlet

Compare water temperature at outlet of the AquaStar (hold the AquaStar's outlet pipe with your hand) and at the tap. If these two are very different, check for mixing valve or plumbing crossover (see "MAIN BURNERS WILL NOT IGNITE..." paragraph #6). Where automatic "anti-scald" valves are required by code, lower the temperature setting on the AquaStar as much as possible and balance the pressure between cold and hot water after the AquaStar.

6. Parts in water flow valve are corroded so that the gas passage is not fully opening.

Contact your service person or Controlled Energy.

HOT WATER TEMPERATURE FLUCTUATES

1. Unbalanced pressure in waterlines

The added restriction caused by the Aquastar in the hot water system can result in uneven pressures between the cold and the hot. In such cases when mixing cold water at the tap, the lower hot water pressure may be overpowered by a much higher cold water pressure, which may cause the Aquastar burners to shut down. Make sure faucet aerators or shower heads are free of minerals. **Do not add any flow restrictor to the shower head.**

2. Cold water is mixing with the hot water between the AquaStar and the outlet

See #6 under "Burners do Not Ignite When Hot Water Turned On".

3. Inlet water pressure is erratic due to inadequate supply water pressure or saturated pressure tank on well system

Check the inlet water pressure. On a private well, raise minimum pressure setting to 30 psi. Confirm that the pressure tank is not water logged.

4. Gas pressure is too low

See page 2 for correct specifications.

Fig. 11 - Diagram of AquaStar 125 B

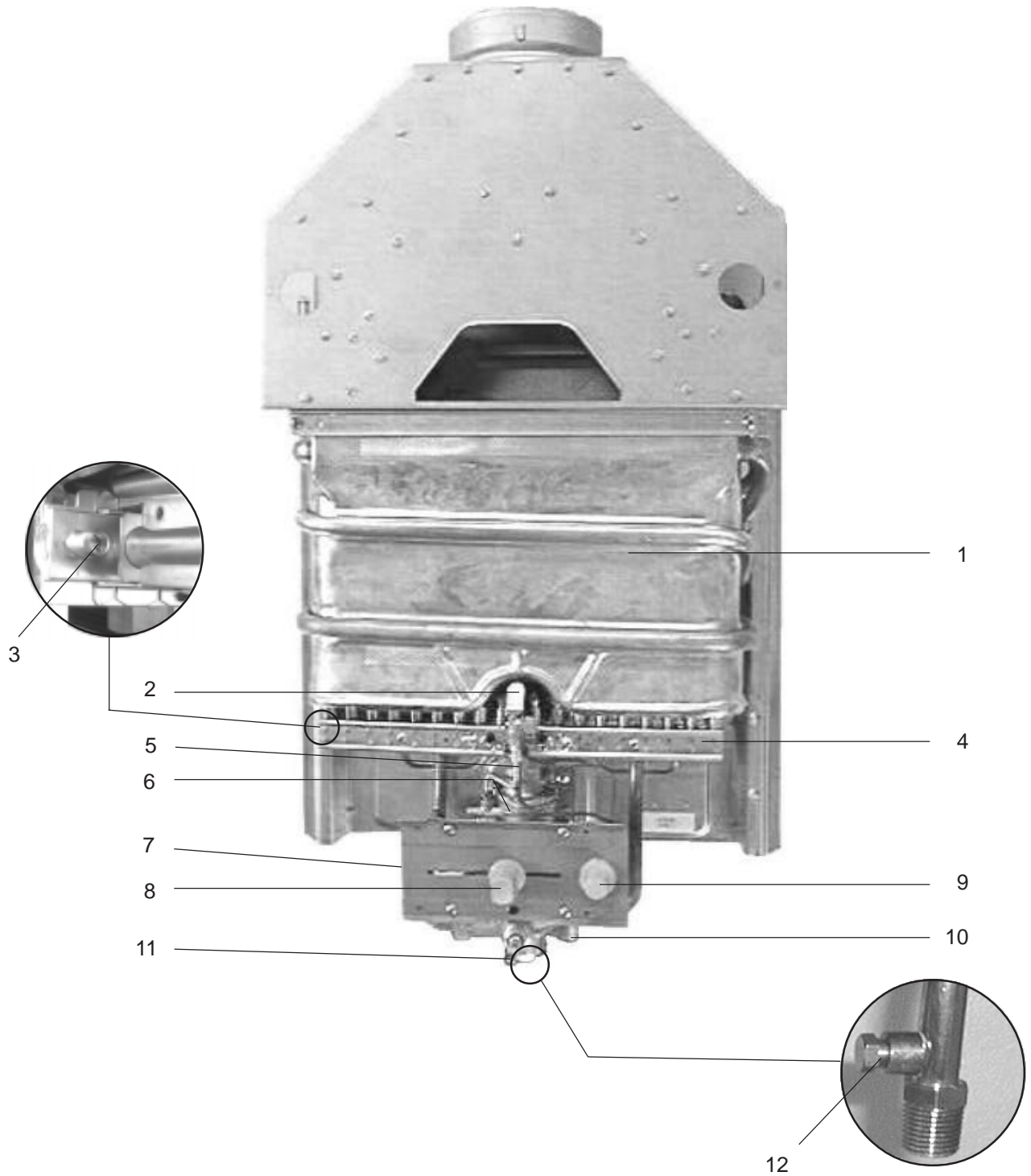

- | | | | |
|----|--|-----|------------------------------------|
| 1. | Heat exchanger | 8. | Gas control slide |
| 2. | Pilot assembly | 9. | Piezo igniter |
| 3. | Burner manifold gas pressure test nipple | 10. | Water valve |
| 4. | Main gas burner | 11. | Temperature adjustment selector |
| 5. | Pilot gas tubing | 12. | Gas inlet gas pressure test nipple |
| 6. | Gas valve | | |
| 7. | Pressure tap screw location | | |

Fig. 12 - INTERIOR COMPONENTS DIAGRAM AND PARTS LIST

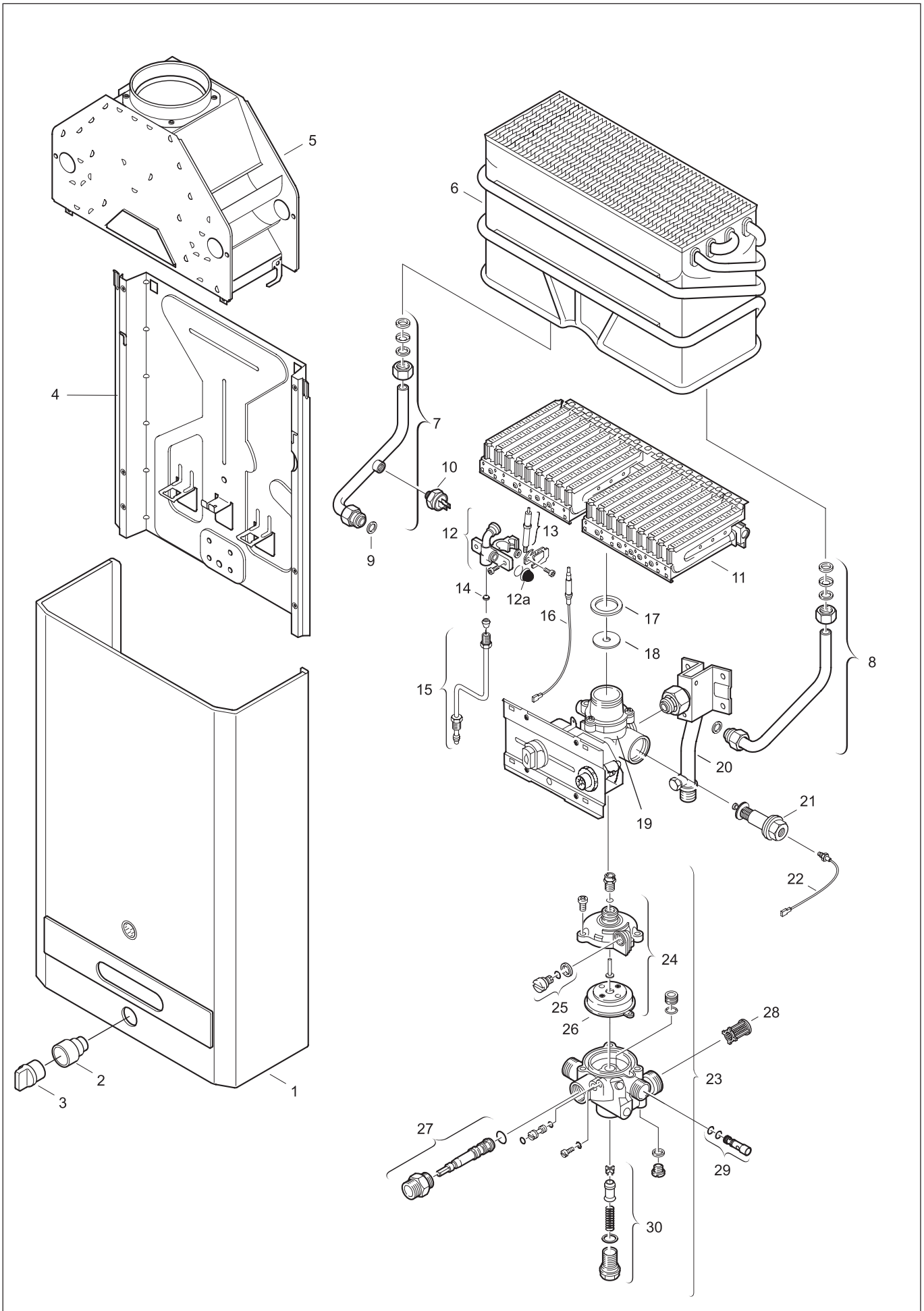

Fig. 12

**INTERIOR COMPONENTS DIAGRAM
AND PARTS LIST 125B**

1	Cover	☒	8 705 421 025
2	Plastic collar	☒	8 700 403 008
3	Temperature adjustment knob	☒	8 702 000 111
4	Panel back	☒	8 705 402 164
5	Draft diverter	☒	8 705 505 354
6	Heat exchanger	☒	8 705 406 235
7	Hot water pipe	☒	8 700 705 556
8	Cold water pipe	☒	8 700 705 294
9	Heat exchanger washer	☒	8 710 103 045
10	Overheat sensor (ECO)	☒	8 707 206 040
11	Main burner assembly	LPG	8 708 120 296
	Main burner assembly	NG	8 708 120 298
12	Pilot burner assembly	☒	8 718 105 048
12a	Pilot air screen	☒	8 700 507 055
13	Piezo electrode	☒	8 708 107 002
14	Pilot orifice	NG	8 708 200 005
	“	LPG	8 748 200 173
15	Pilot Tube	☒	8 700 707 320
16	Thermocouple	☒	8 747 202 083
17	Burner assembly washer	☒	8 710 103 060
18	Throttle disc	LPG	8 700 100 174
19	Gas valve	LPG	8 707 011 463
	Gas valve	NG	8 707 011 459
20	Gas supply pipe	☒	8 700 705 552
21	Electromagnet	☒	8 707 201 012
22	Thermocable	☒	8 747 202 209
23	Water valve assembly	☒	8 707 002 499
24	Water valve repair kit	☒	8 703 406 178
25	Slow ignition valve	☒	8 708 503 063
26	Water valve diaphragm	☒	8 700 503 053
27	Water valve selector screw assembly	☒	8 708 500 251
28	Water inlet filter	☒	8 700 507 045
29	Water valve venturi	☒	8 708 205 249
30	Water valve water governor	☒	8 707 402 013



INSTALLATION CHECKLIST

GAS LINE SIZE

Natural Gas

Nominal Iron Pipe Size*	1/2"	3/4"	1"	
MAXIMUM LENGTH	10'	40'	150'	

Liquid Propane

Semi-rigid Tubing	1/2"	5/8"	3/4"	7/8"
MAXIMUM LENGTH	NOT RECOMMENDED	20'	60'	150'

* Flex tubing greatly reduces capacity and, therefore, is not recommended.

Minimum Vent Size* and Height

Minimum Diameter	Minimum Height**
5 inches	6 feet**

* **NOTE:** Vent size must not be restricted. Installation must comply with national fuel gas code venting requirements for a 117,000 Btu Category I appliance and any applicable local codes.

** **NOTE:** Minimum vent height must be 6 feet, provided there are no elbows. Termination of the vent must be 2 feet above any obstruction within a 10 foot radius of vent pipe. Consult your gas utility or National Fuel Gas Code if vent will have elbows or share venting with another appliance. The vent connector should have as much vertical rise as possible (minimum 12") before any horizontal run.

Water Pressure

For installation on well systems, insure that your water pressure is between 30 - 50 psi.

Replacement Parts available from North American Distributor

CONTROLLED ENERGY CORP.

340 Mad River Park
 Vermont 05673 (U.S.A.)
 Phone 800-642-3111
 Fax (802) 496-6924

WWW.CECHOT.COM techsupport@cechot.com

VULCANO Termodomésticos S.A.
 Estrada de Cacia
 3800 Cacia - PORTUGAL